

 STELLA 

 Powered by  
**anubesport**<sup>®</sup>

# SCHERMATA PRINCIPALE



NUMERO WAYPOINT  
DI ARRIVO

NOME WAYPOINT  
DI ARRIVO

DIREZIONE

CONTA CHILOMETRI  
TOTALE

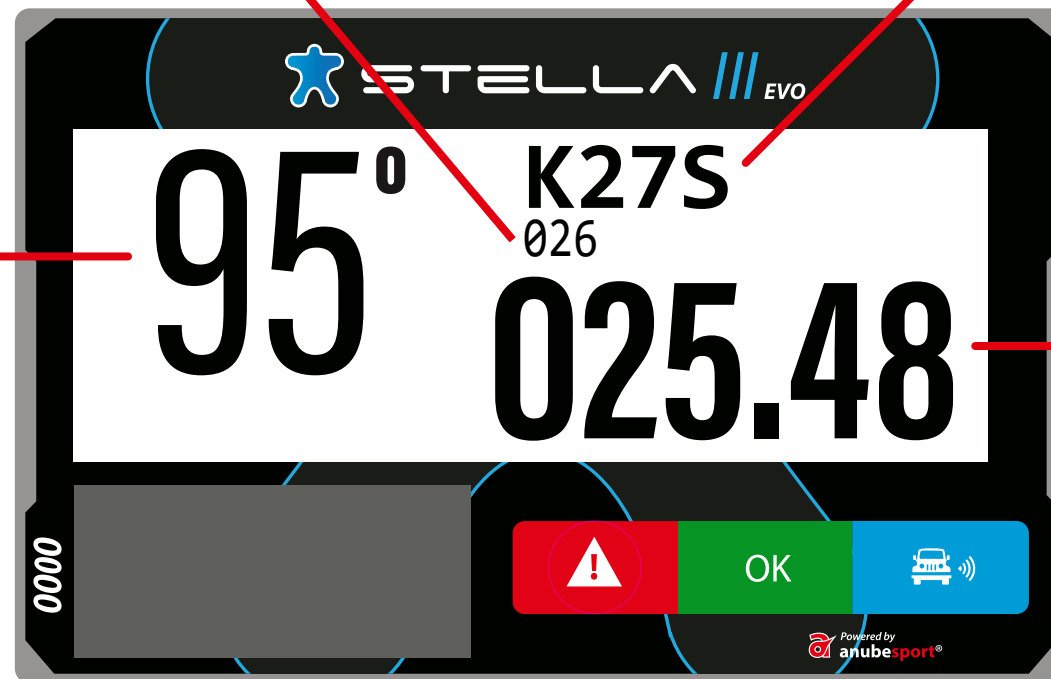

# WAYPOINT IN AVVICINAMENTO



**DIREZIONE DEL WAYPOINT DI ARRIVO**

**DIREZIONE**

**DISTANZA DAL WAYPOINT**

**CONTA CHILOMETRI TOTALE**

STELLA EVO

026 K27S

512

320°

026.82

0000

! OK

Powered by anubespport

Detailed description: The image shows a navigation device screen for 'STELLA EVO'. The screen displays a large circular arrow icon with a black triangle pointing towards the top-right, indicating the direction to the waypoint. To the right of the icon, the text '026 K27S' is shown at the top, '512' in the middle, and '320°' in large font at the bottom. To the right of the '320°' is the text '026.82'. At the bottom of the screen, there are three buttons: a red button with a white exclamation mark, a green button with 'OK', and a blue button with a white car icon and signal waves. On the left side of the screen, the number '0000' is visible vertically. The device has a black bezel with blue accents. Red lines connect the text labels to the corresponding elements on the screen.

# ZONA DI VELOCITÀ

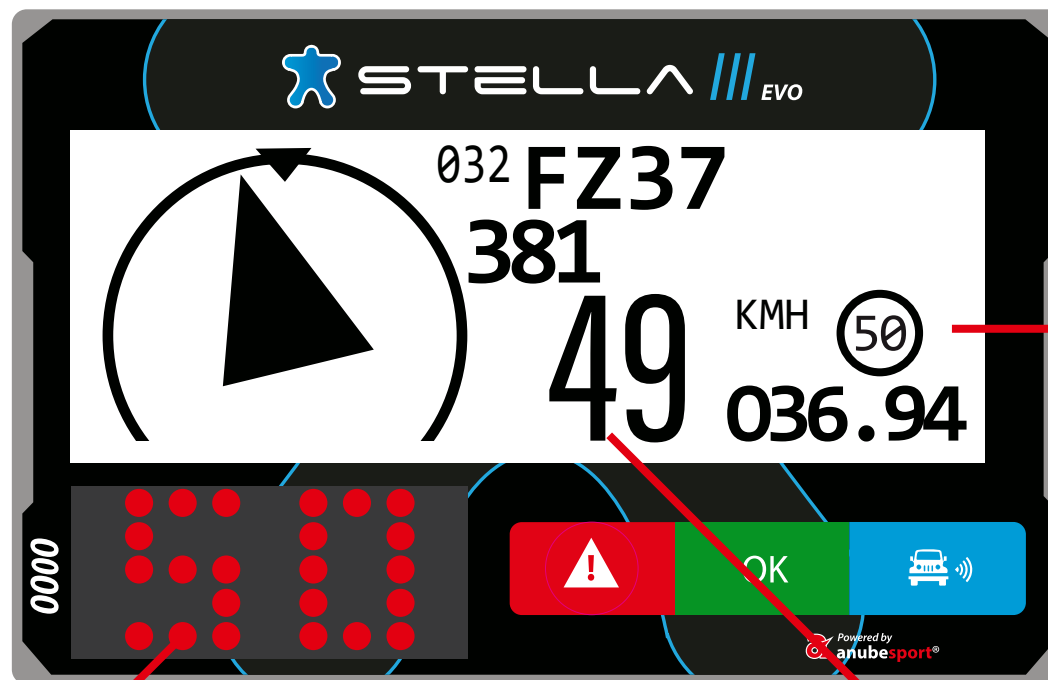

LIMITE  
DI VELOCITÀ

LIMITE  
DI VELOCITÀ

VELOCITÀ REALE

# RICHIESTA DI IMMEDIATO INTERVENTO MEDICO

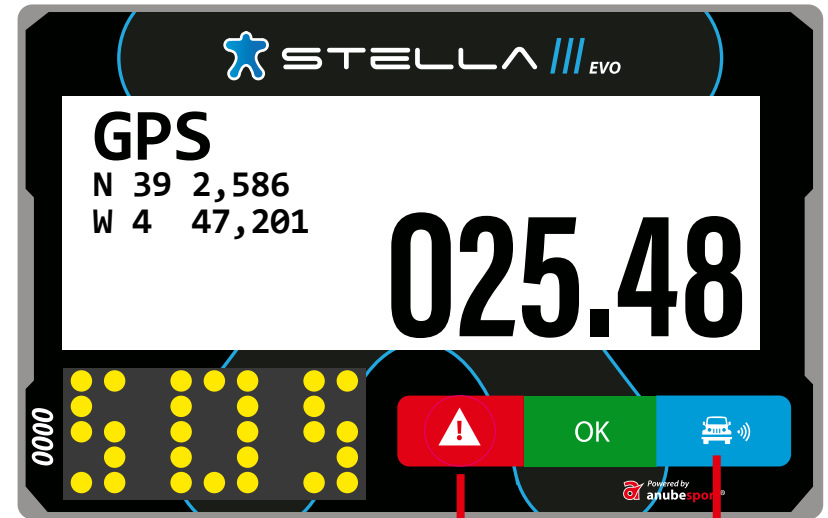
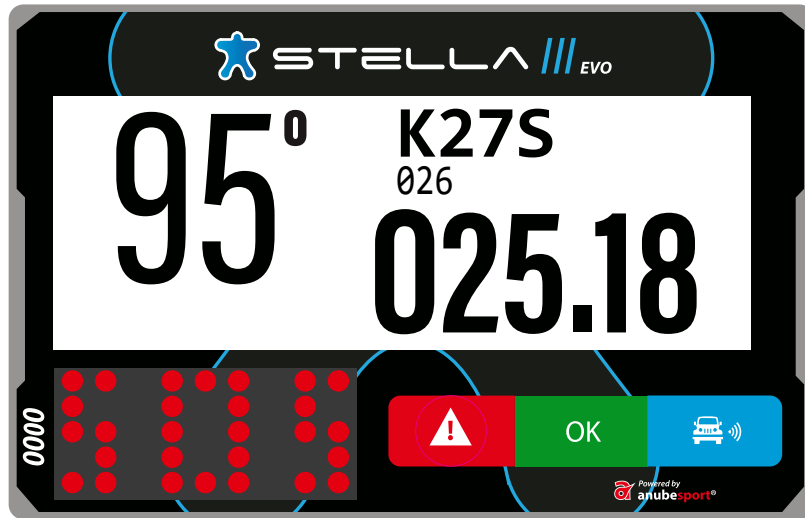

1 sec.

SOS

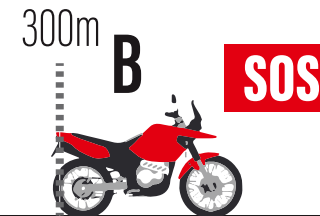
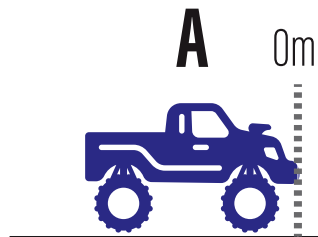

# AVVISO DI VEICOLO FERMO

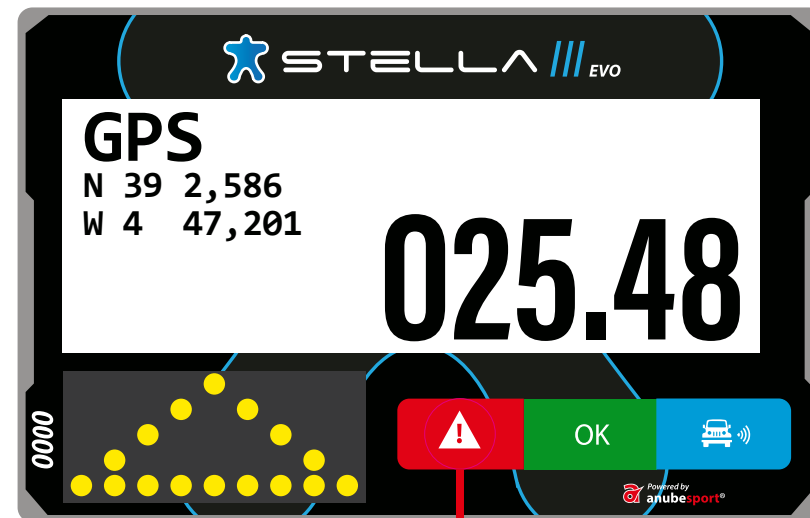
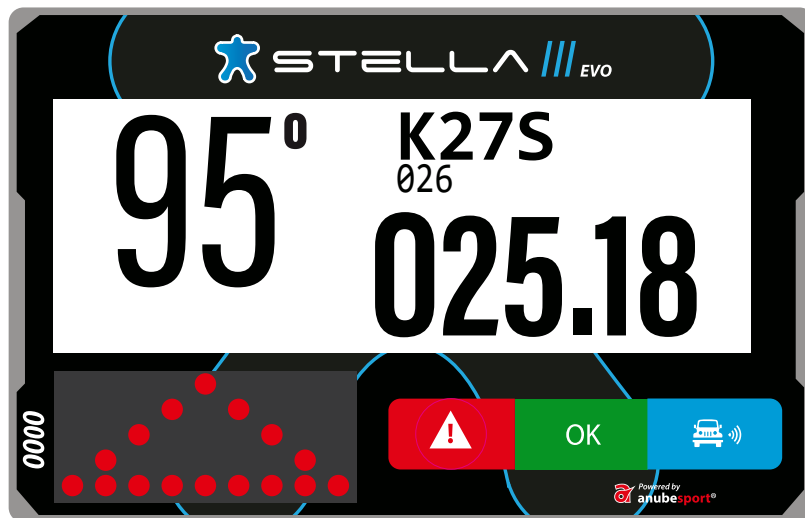

3 sec.

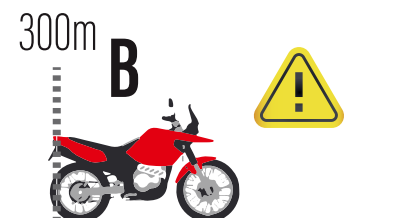
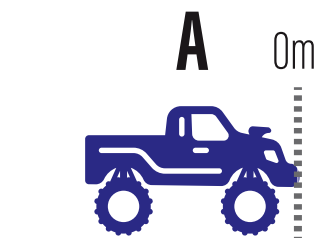

# PERICOLO 3!!!

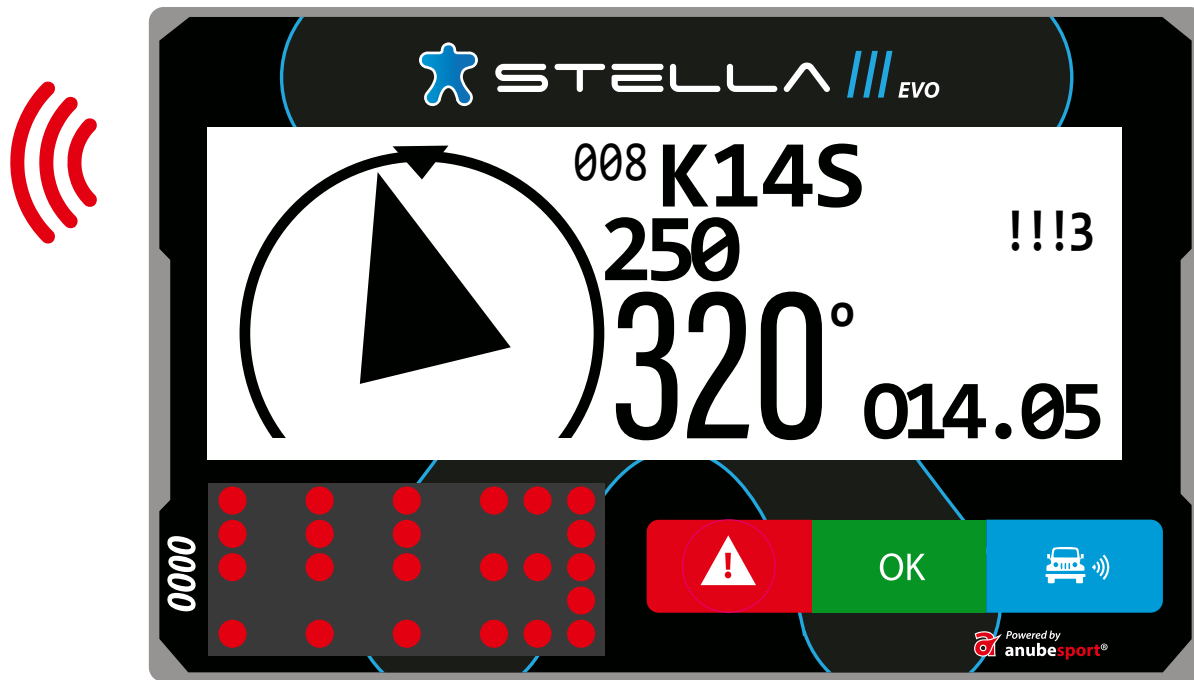

Preavviso di 300m sulla nota del road book di "pericolo 3!!!"

# AVVISO DI SORPASSO



LAMPEGGIANTE

RICHIESTA DI SORPASSO





# AVVISO DI SORPASSO

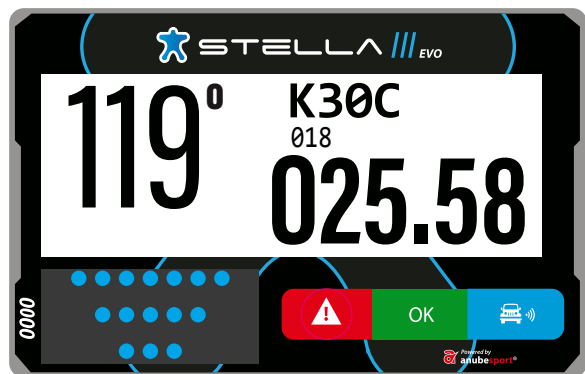

**FISSO**

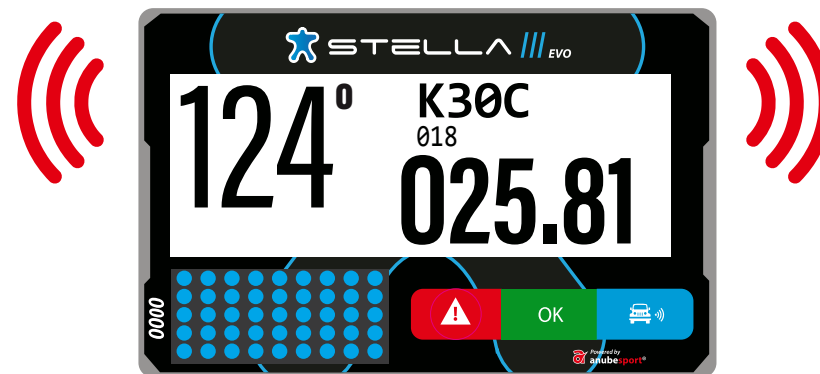

**LAMPEGGIANTE**



# AVVISO DI SORPASSO

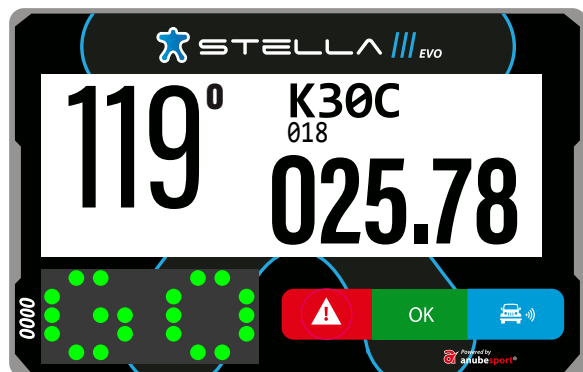

**LIBERTÀ DI SORPASSO**

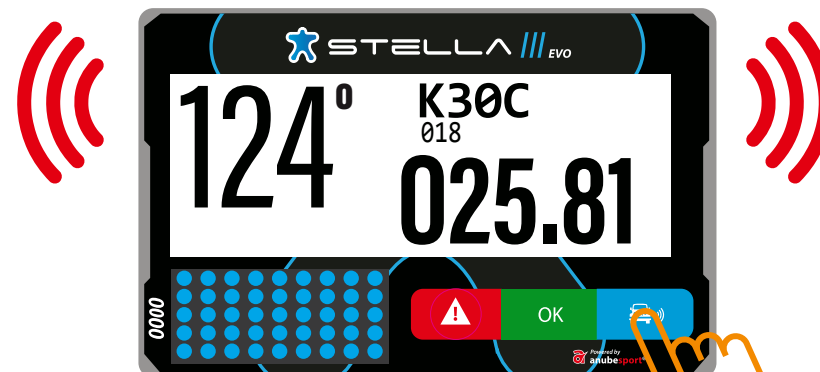

**FISSO**

**PREMERE IL PULSANTE BLU  
PER CONFERMARE**

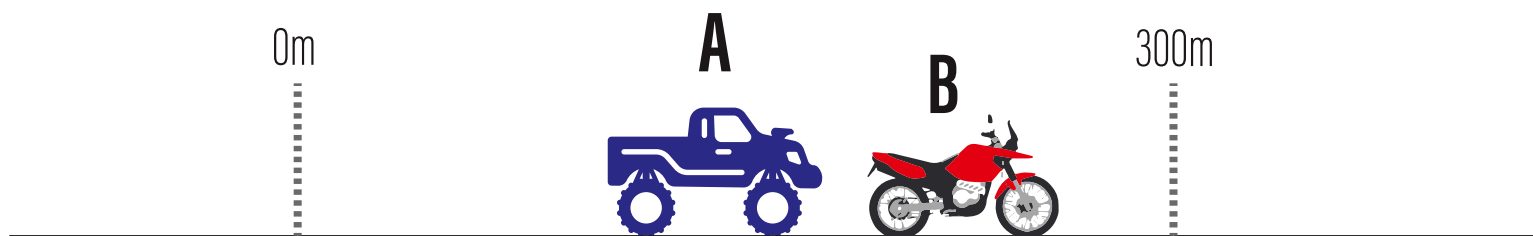

# LIMITE DI VELOCITÀ

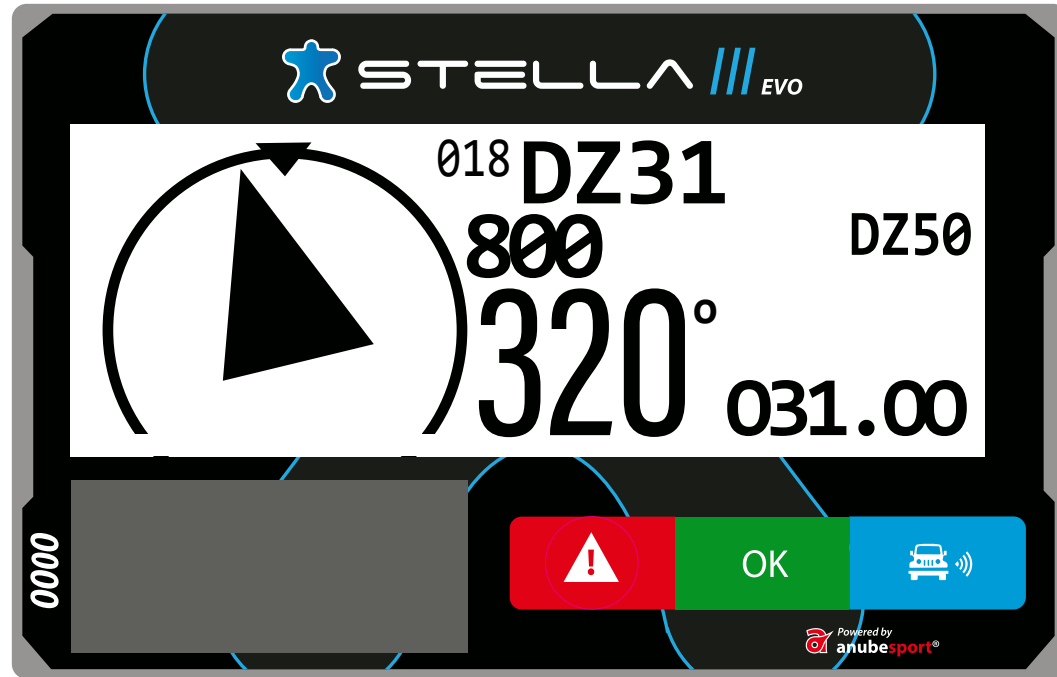

# LIMITE DI VELOCITÀ



**GIALLO**  
90m di tolleranza  
in entrata area  
velocità controllata

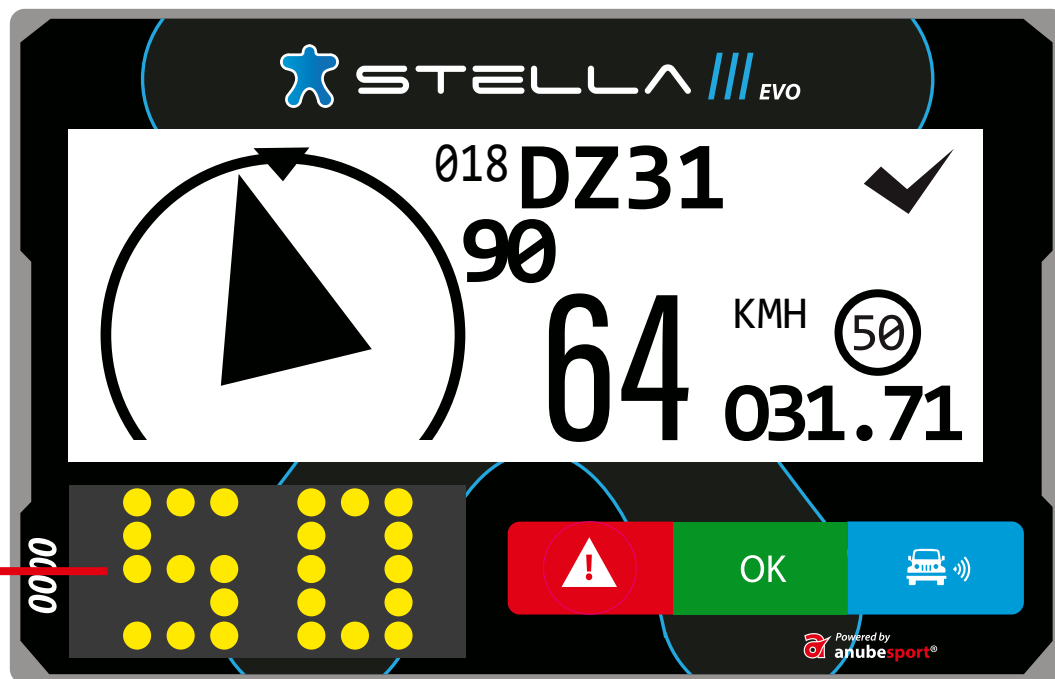

# LIMITE DI VELOCITÀ



**ROSSO FISSO**  
dentro area velocità controllata

**ROSSO LAMPEGGIANTE**  
eccesso di velocità

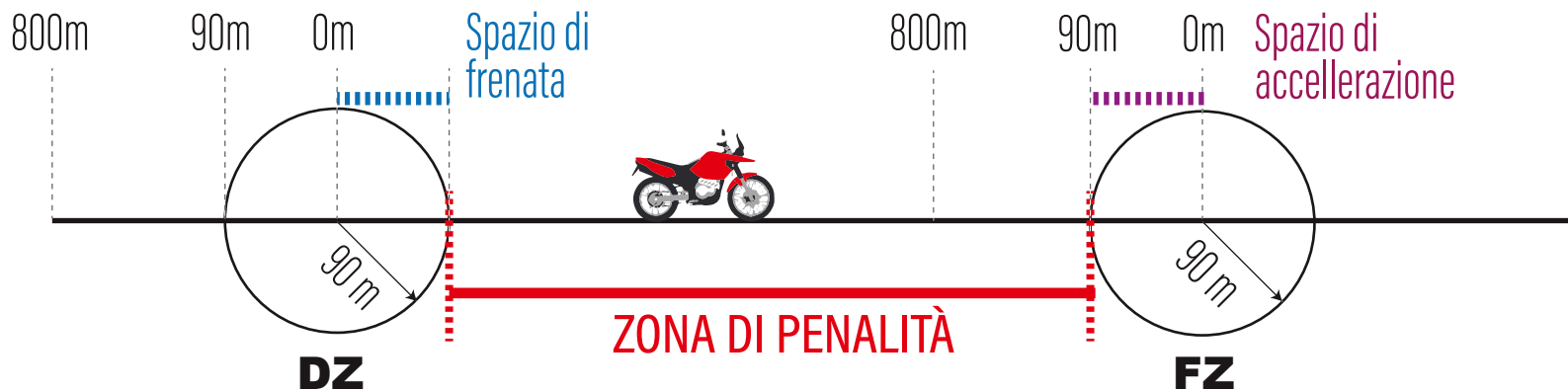
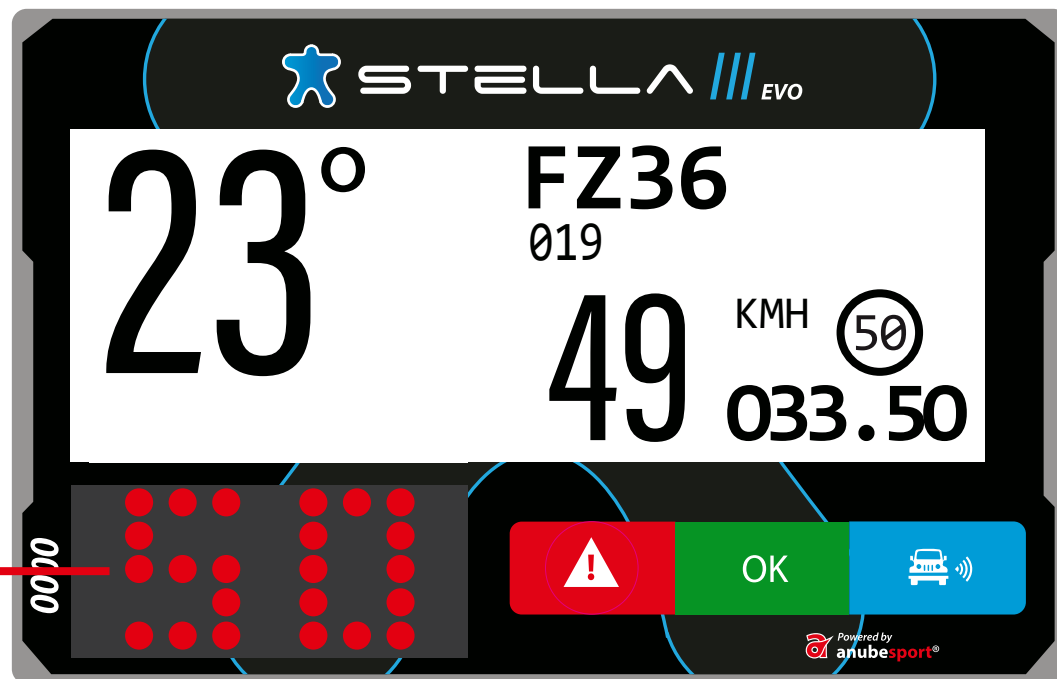

# LIMITE DI VELOCITÀ



**SPENTO**  
fine della zona  
di velocità  
controllata

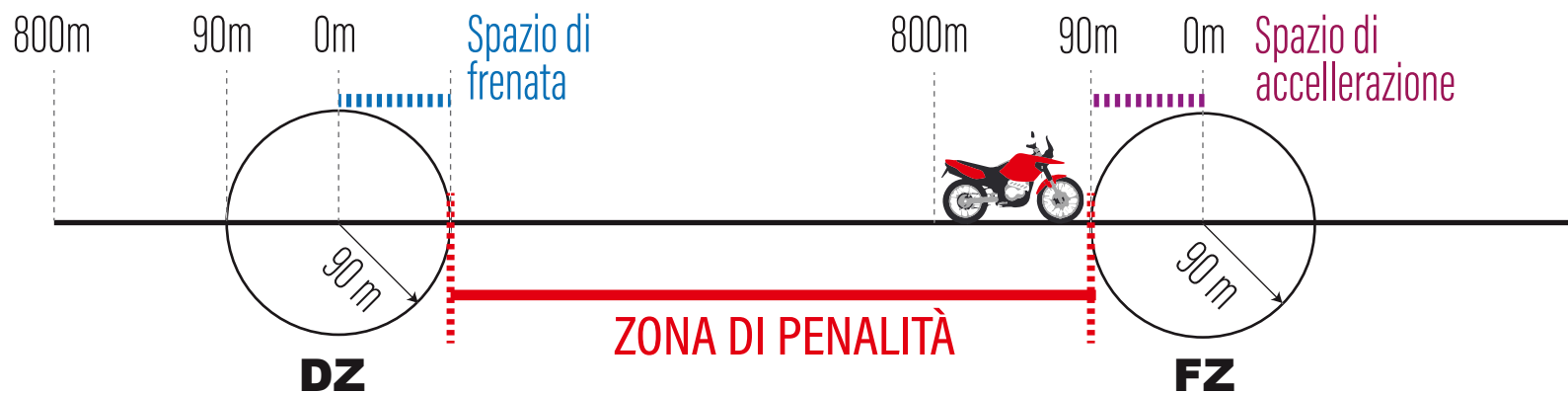
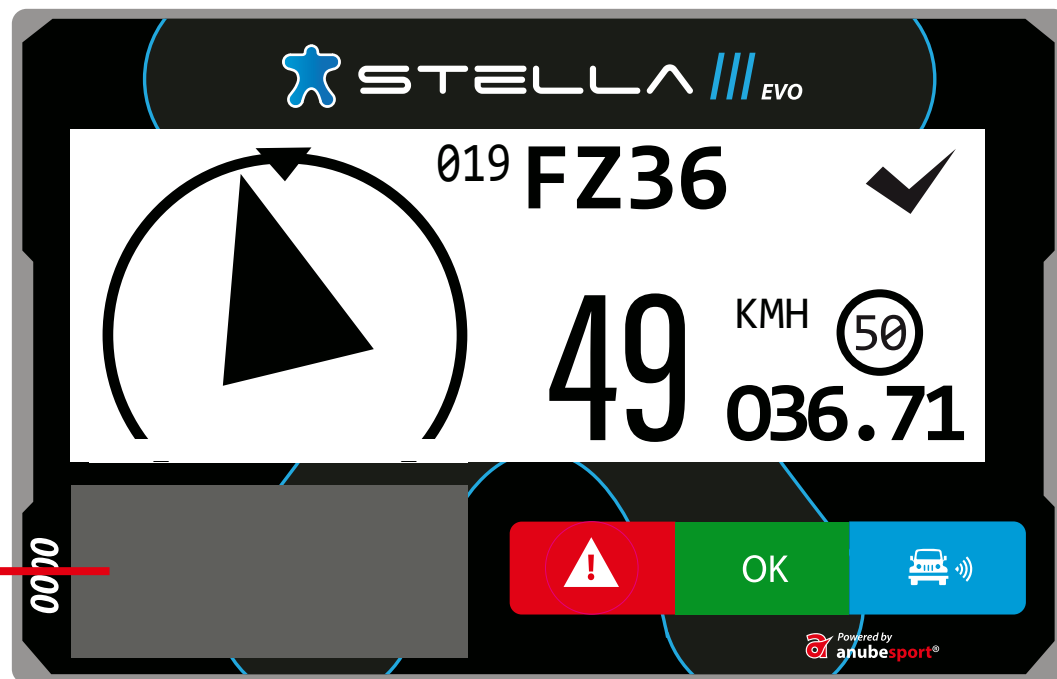

# ZONA NEUTRALIZZATA

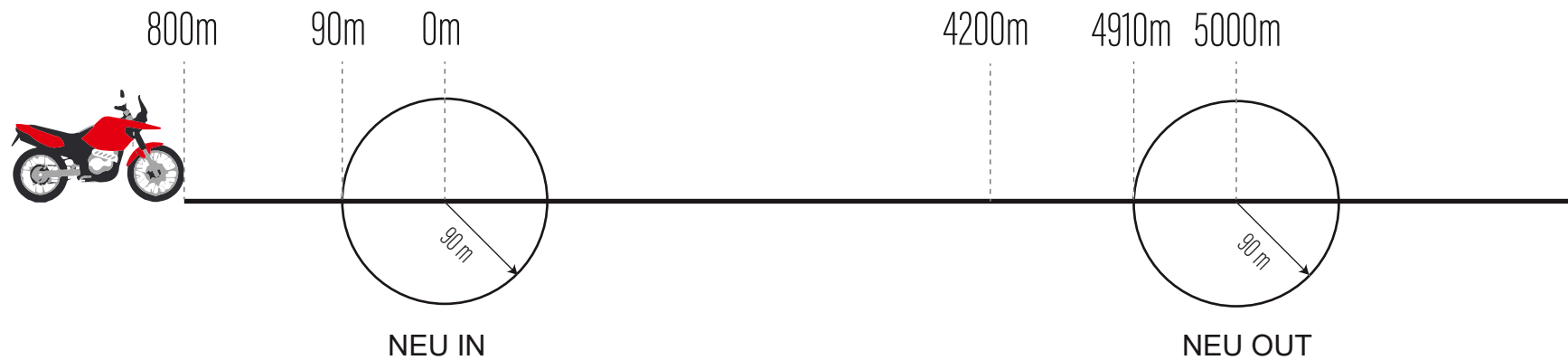
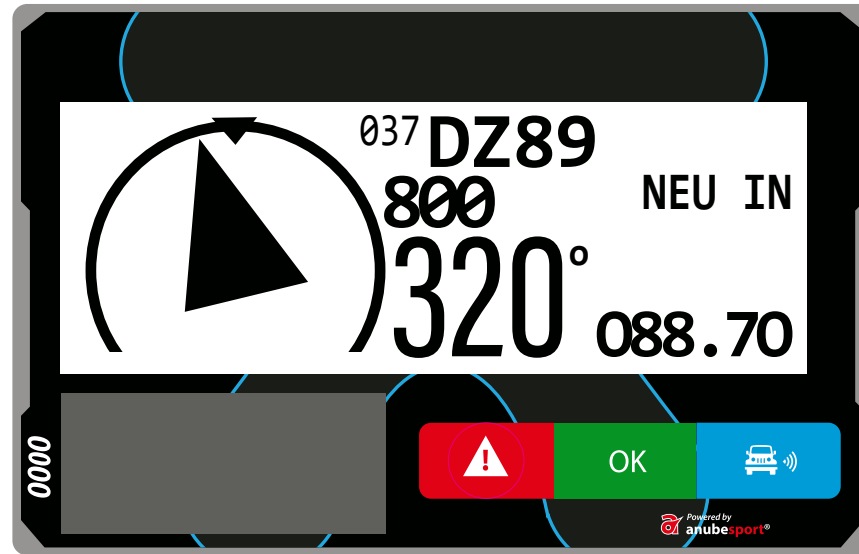

# ZONA NEUTRALIZZATA

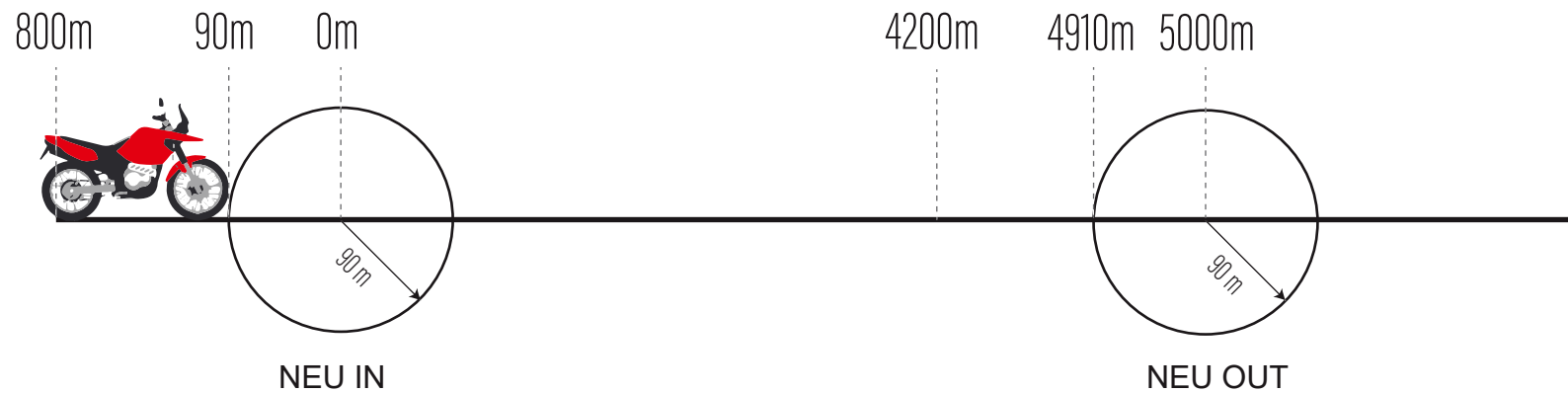
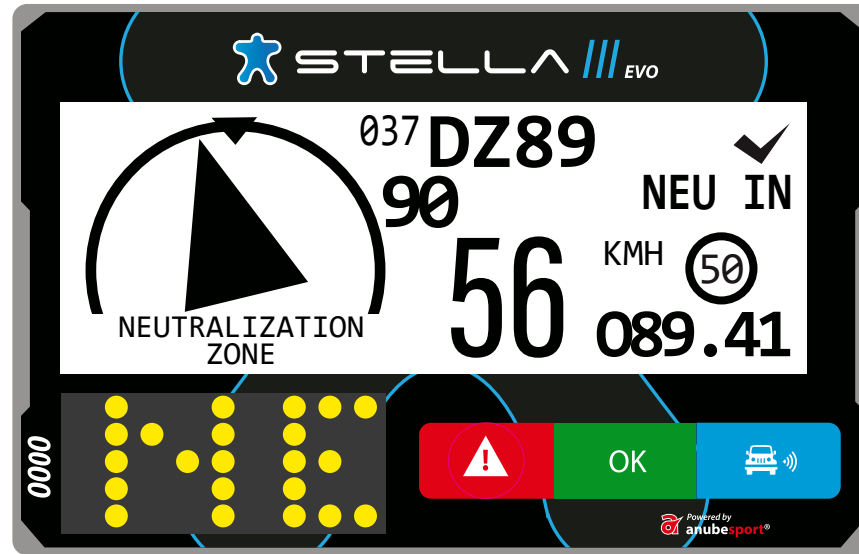



# ZONA NEUTRALIZZATA

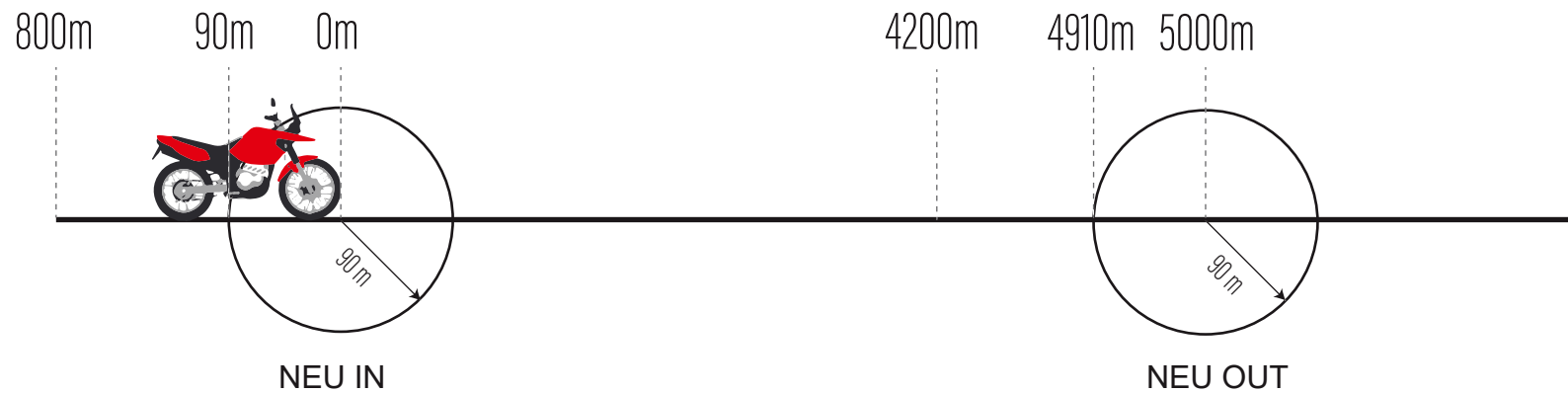
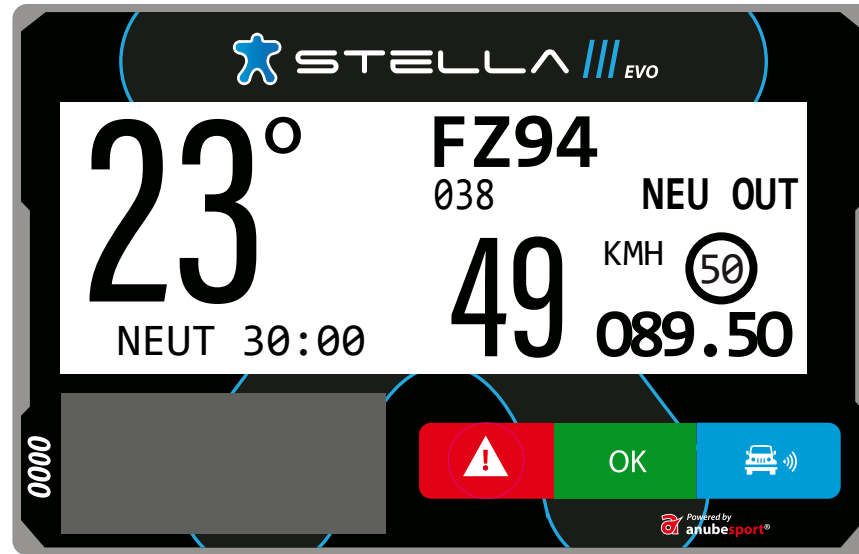

# ZONA NEUTRALIZZATA

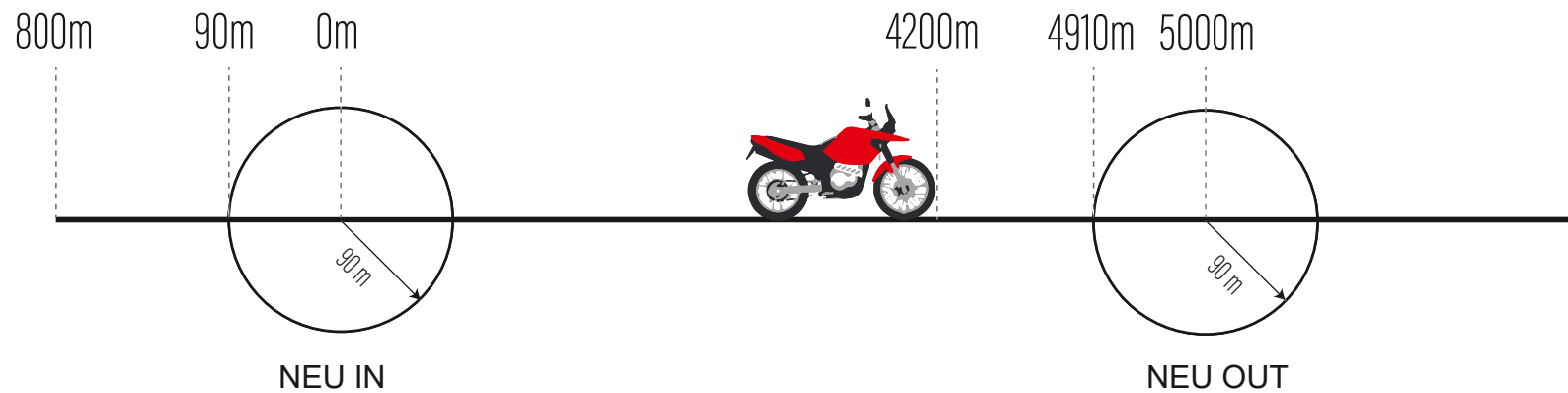
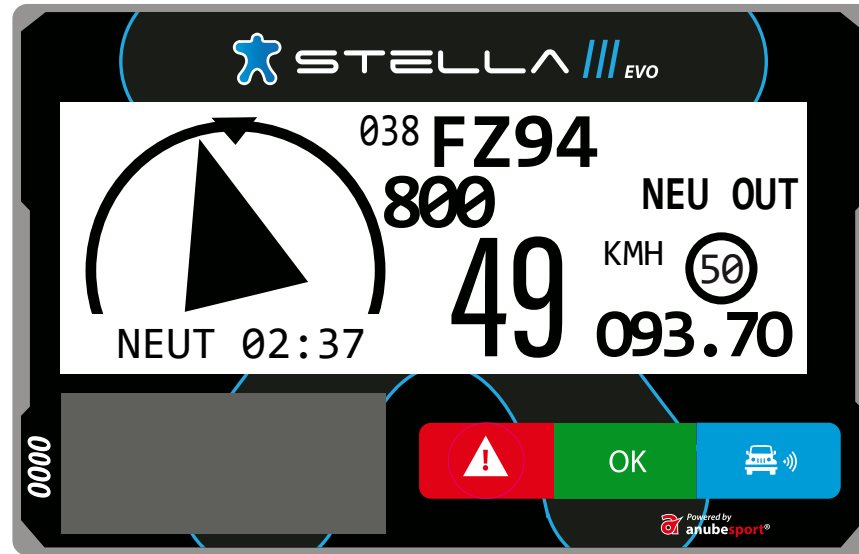

# ZONA NEUTRALIZZATA

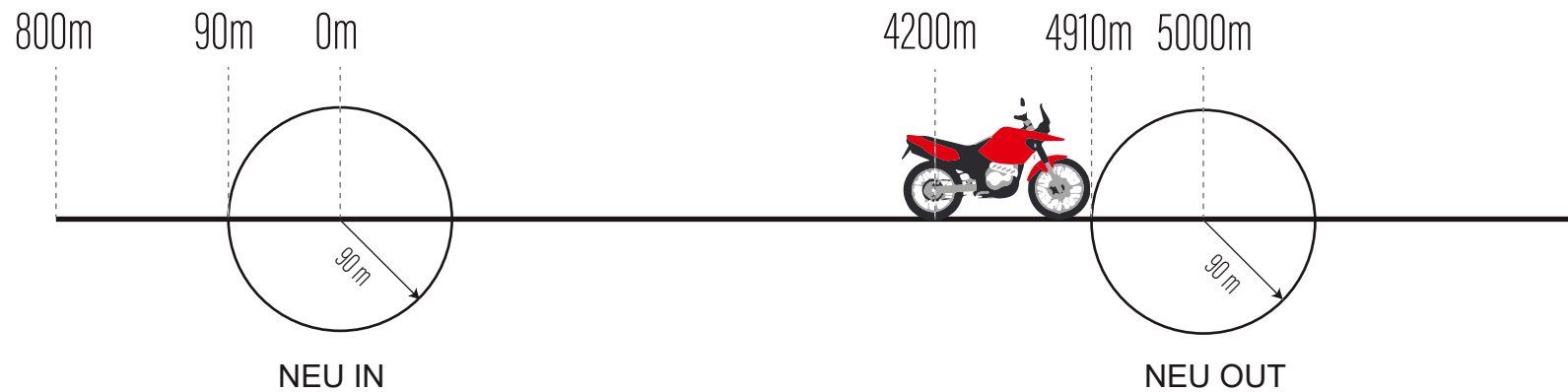
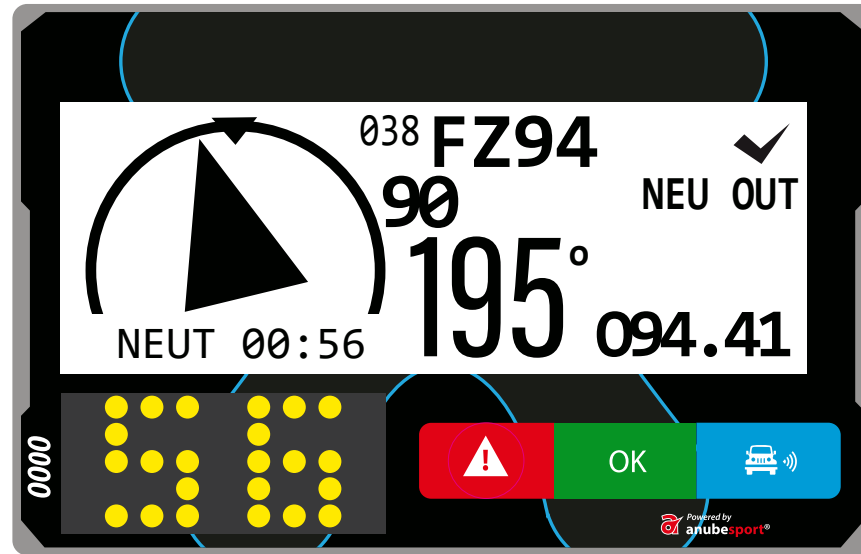

# ZONA NEUTRALIZZATA

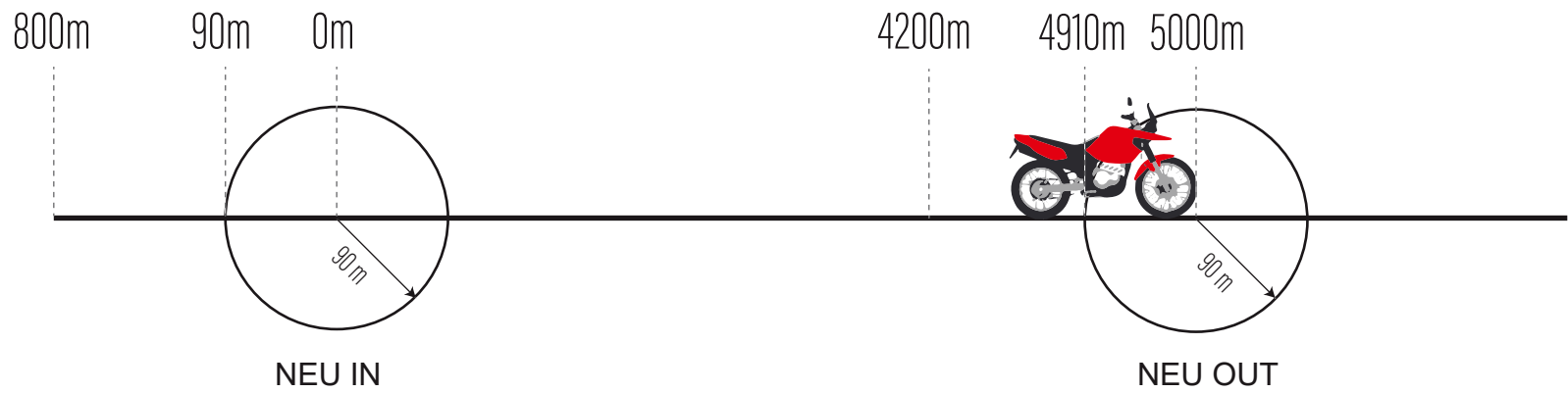
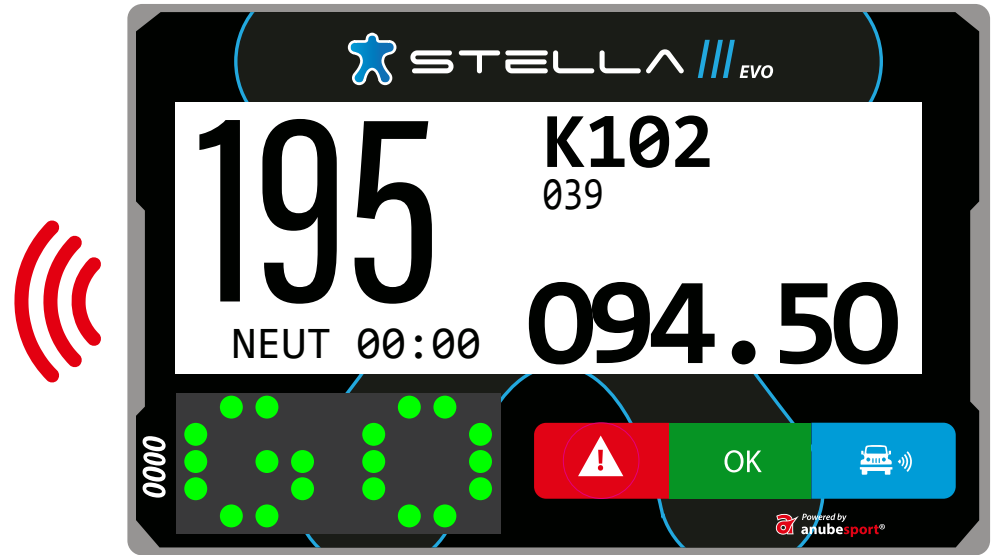

# MESSAGGI



STELLA /// EVO

**STAI BENE/TUTTO A POSTO?**

NO SI

0000

⚠️ OK 🚗

Powered by anubespport

Detailed description: This is a rectangular screen with a black background and rounded corners. At the top, it features the 'STELLA /// EVO' logo in white. The main display area is white and contains the text 'STAI BENE/TUTTO A POSTO?' in bold black letters. Below the text, there are two options: 'NO' on the left and 'SI' on the right, each with a small black downward-pointing arrow. At the bottom of the screen, there is a grey rectangular area on the left containing six yellow dots in a 2x3 grid. To the right of this is a horizontal bar with three colored sections: a red section with a white warning triangle icon, a green section with the text 'OK', and a blue section with a white car icon and a signal icon. The number '0000' is printed vertically on the left side of the screen. At the bottom right corner, there is a small logo for 'Powered by anubespport'.



STELLA /// EVO

**RICHIESTA MEDICA?**

NO SI

0000

⚠️ OK 🚗

Powered by anubespport

Detailed description: This is a rectangular screen with a black background and rounded corners. At the top, it features the 'STELLA /// EVO' logo in white. The main display area is white and contains the text 'RICHIESTA MEDICA?' in bold black letters. Below the text, there are two options: 'NO' on the left and 'SI' on the right, each with a small black downward-pointing arrow. At the bottom of the screen, there is a grey rectangular area on the left containing six yellow dots in a 2x3 grid. To the right of this is a horizontal bar with three colored sections: a red section with a white warning triangle icon, a green section with the text 'OK', and a blue section with a white car icon and a signal icon. The number '0000' is printed vertically on the left side of the screen. At the bottom right corner, there is a small logo for 'Powered by anubespport'.



STELLA /// EVO

**STRADA ERRATA/SBAGLIATA!**

OK

0000

⚠️ OK 🚗

Powered by anubespport

Detailed description: This is a rectangular screen with a black background and rounded corners. At the top, it features the 'STELLA /// EVO' logo in white. The main display area is white and contains the text 'STRADA ERRATA/SBAGLIATA!' in bold black letters. Below the text, there is a single option: 'OK' with a small black downward-pointing arrow. At the bottom of the screen, there is a grey rectangular area on the left containing six yellow dots in a 2x3 grid. To the right of this is a horizontal bar with three colored sections: a red section with a white warning triangle icon, a green section with the text 'OK', and a blue section with a white car icon and a signal icon. The number '0000' is printed vertically on the left side of the screen. At the bottom right corner, there is a small logo for 'Powered by anubespport'.



STELLA /// EVO

**I SOCCORSI STANNO ARRIVANDO**

OK

0000

⚠️ OK 🚗

Powered by anubespport

Detailed description: This is a rectangular screen with a black background and rounded corners. At the top, it features the 'STELLA /// EVO' logo in white. The main display area is white and contains the text 'I SOCCORSI STANNO ARRIVANDO' in bold black letters. Below the text, there is a single option: 'OK' with a small black downward-pointing arrow. At the bottom of the screen, there is a grey rectangular area on the left containing six yellow dots in a 2x3 grid. To the right of this is a horizontal bar with three colored sections: a red section with a white warning triangle icon, a green section with the text 'OK', and a blue section with a white car icon and a signal icon. The number '0000' is printed vertically on the left side of the screen. At the bottom right corner, there is a small logo for 'Powered by anubespport'.

# LISTA WAYPOINT



OK

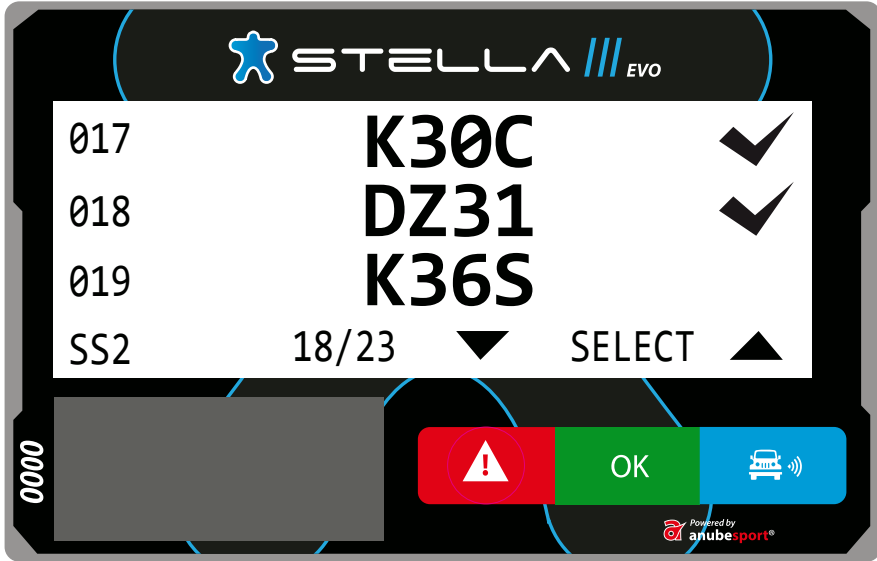
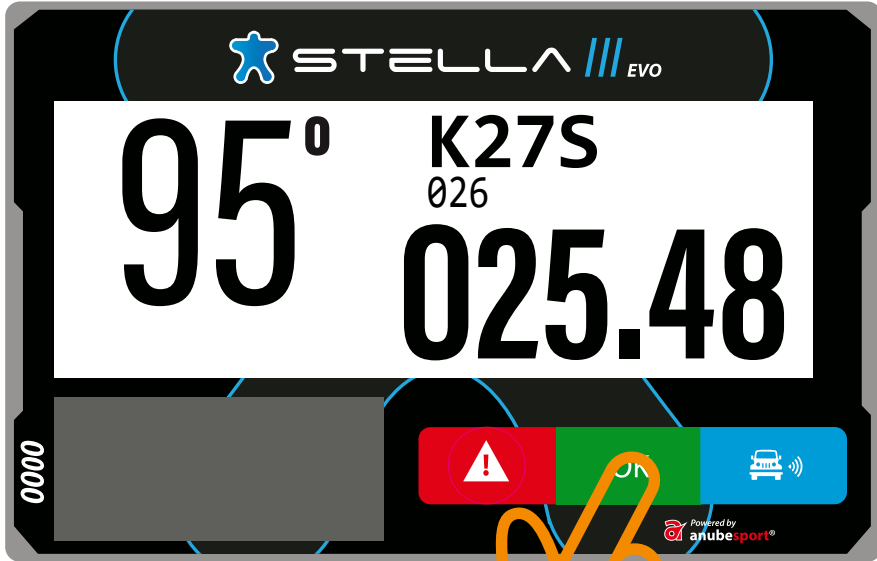

# AZZERAMENTO CONTA CHILOMETRI TOTALE



OK

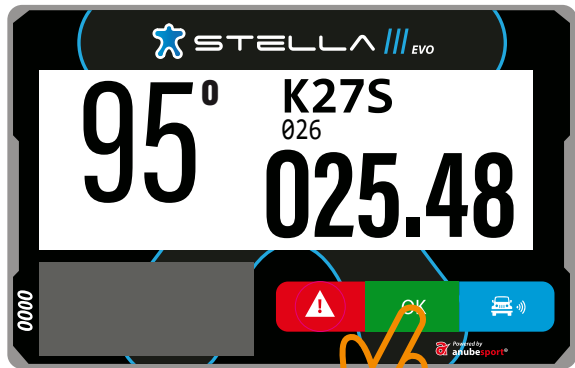

1 sec.

+

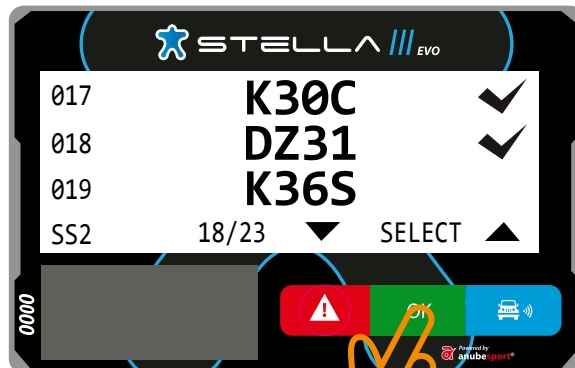

1 sec.

+

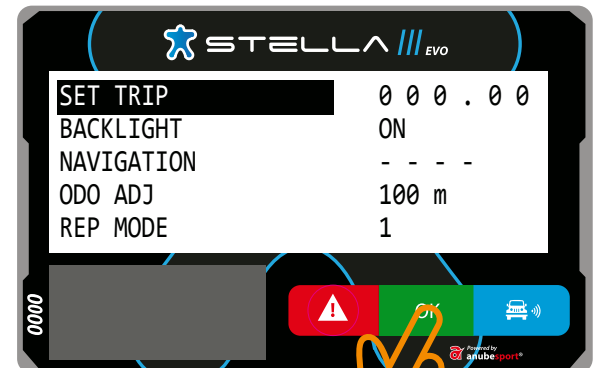

1 sec.

 STELLA 

Powered by  
 **anubesport**<sup>®</sup>